

4S-700B

Mobile Oil Filter System for Workshop & Industrial Deployment

- Stainless steel construction
- 4 microfiltration units SDU-H8 incl. 4 filter elements SDFC
- Filtration performance (average value) 480 l/h (40 cSt)
- For oil quantities up to 5,000 litres
- Self-priming gear pump
- Large pre-filter unit with washable filter bag
- Overpressure protection
- Pressure gauge
- IP rating: IP55
- Transfer function-
movement of the oil without filtration
- 6m suction and return hose with
quick release couplings
- Starting viscosity: max. 1,000 cSt.
Filtration viscosity: < 200 cSt.



Results

Water Removed



Removes free and dissolved water contamination

Particles Removed



Achievable oil cleanliness / cleanliness class in the ideal case: 13/11/8 (ISO 4406: 1999) / Class 2 (NAS 1638) - better than new oil quality levels

Benefits

- Removes and minimizes microparticles & varnish
- Removes free and dissolved water contamination
- Increases system reliability
- Prevents system corrosion (water!)
- Less component wear
- Longer oil change intervals; CO₂ -reduction
- Reduced operating costs
- MINIMESS Test Points

Application Examples

This offline mobile filter system with the SDFC filter elements fitted as standard is suitable for filtration of mineral oil based and/or synthetic, non water-based lubricants and pressure fluids. It is ideal for application in all service-workshops or manufacturing plants such as,

- Power generation
- Plastic moulding
- Production of raw materials
- Every kind of industry where oils are employed

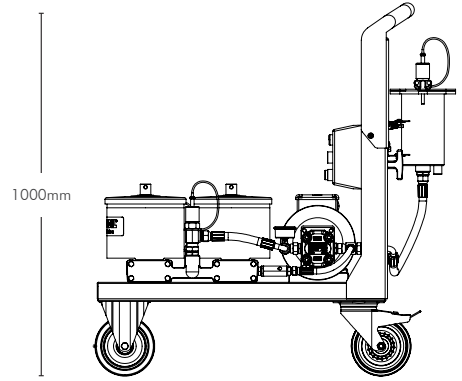
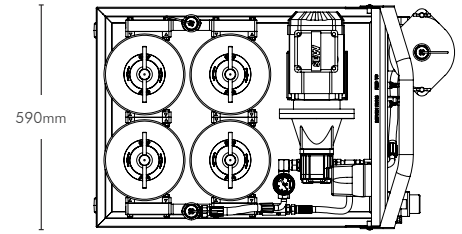

967mm

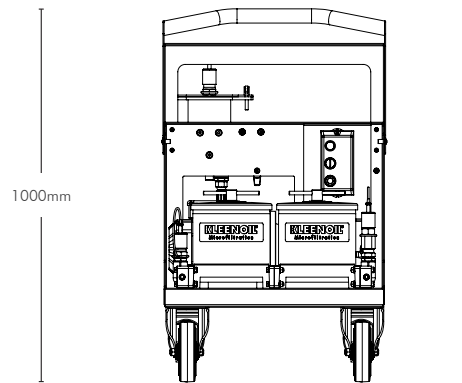

Type	Recommended Installation	Max. Operating Temp.	IP Rating	Flow rate (average value at < 40 cSt.) l/h	Pump Suction Lift	Voltage/ Motor Performance/ Current Draw	Dimensions (mm)		Weight (kg)	Filter Element Type	Retention Capacity per Element (x4)	
							H	W			Dirt: ≤ 2 kg	Water: ≤ 0.5 l
4S-700B	Mobile offline filtration system. Installation: Taking feed and return from hydraulic reservoir / tank. For systems up to 5,000 l.	60°C	IP55	480	Self-priming to 5.5 m	230 Volt / 50 HZ 0,55 KW ≤ 4.0 Amps. (Motor)	1000	590	95	Standard fit: 4 x SDFC (oil based fluids & fuels)	≤ 2 kg	≤ 0.5 l
							L					
							967					

KLEENOIL PANOLIN AG

Schnötring 2-3 79804 Dogern Deutschland
T. +49 7751 8383-0 F. +49 7751 8383-29 E. info@kleenoil.com
www.kleenoilpanolin.com

The specification and photography above is for reference only and may be subject to change.
KLEENOIL is a trademark of the company KLEENOIL PANOLIN AG. © KLEENOIL PANOLIN AG. All rights reserved.

KLEENOIL[®]
Microfiltration